

High Voltage Resistive Loads

Table of Contents

Why resistive loads are necessary	1
How to design a resistive load	1
How to construct a resistive load	2
How to safely use a resistive load	3

Why resistive loads are necessary

To fully test a high voltage power supply, it is necessary to draw current from the supply. This current may be the maximum rated current in which case the supply will output its maximum power, or it may be a portion of the rated current. In either case, to draw current it is necessary to connect the supply to a resistive load. However, a load is not an off-the-shelf item. This article will discuss how to design and build a high voltage resistive load.

A resistive load may be a useful device to have for other reasons. In many applications, the actual load that a supply will see is not a purely resistive load. It may also contain inductive and/or capacitive elements. Occasionally, the connection to this type of a load can adversely affect the performance of the power supply. To see if this is the case, it is desirable to be able to connect the supply to a purely resistive load. If the performance is then normal with a resistive load, this test may indicate that the problem is being caused by the interaction of the actual load with the power supply.

How to Design A Resistive Load

The design of a high voltage resistive load is straightforward, but not necessarily a simple task. Although resistors are manufactured with voltage ratings in the kilovolts, they are expensive and not readily available. In addition, they may not be capable of dissipating the available power without damage. A simpler and less expensive alternative is to use a series string of resistors. Each series string consists of lower resistance, wattage, and voltage capability. Each series string is physically arranged and mounted in such a way as to avoid any paths for voltage breakdown while also allowing for the proper dissipation of heat.

Voltage Breakdown

The following curve can be used to estimate voltage breakdown levels as a function of the spacing between pointed electrodes under standard atmospheric conditions. Air contaminants, such as dust and fibers, altitude, and high humidity can significantly lower these breakdown values. These voltage breakdown levels can be increased significantly if broad and smoothly rounded electrodes are used instead of pointed electrodes. Such rounded electrodes avoid the ionization of the surrounding air and subsequent corona discharge or arcing. **XP Glassman recommends a conservative 5kV/in be used for the design spacings to account for environmental variations and safety.**

Normal design precautions are adequate for resistive loads that will be used with power supplies up to approximately 10 kW. However, considerations of voltage breakdown, including the possibility of corona leakage and discharge, become increasingly important above 10 kW.

Figure 1

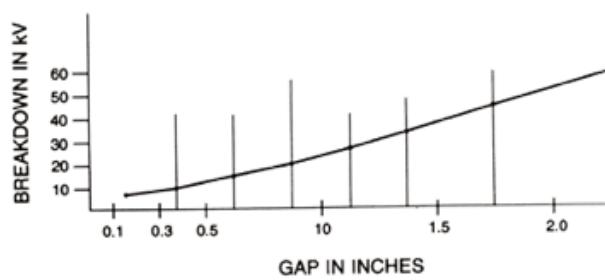

Our first example of the design of a resistive load is for a relatively low voltage application where voltage breakdown is not a problem but power dissipation is definitely a problem. Later we will provide examples where voltage breakdown also must be considered.

Consider the following design equations, where:

V = maximum voltage applied to load.

P = power dissipated in R = V x I.

If:

P_n = power dissipated in each individual load resistor.

Then:

n = number of series load resistors required = P/P_n.

R_n = resistance of each series load resistor = R/n.

V_n = voltage drop across each series load resistor = V/n.

For example, to design a resistive load for the following conditions:

V = 10 kV

I = 300 mA

P_n = 25 W

Then:

R = V/I = 10 kV/300 mA = 33.3 k ohm.

P = V x I = 10kV x 300 mA = 3 kW.

n = P/P_n = 3 kW/25 = 120.

R_n = R/n = 33.3 k ohm/120 = 277.5.

V_n = V/n = 10 kV/120 = 83.3 V.

To construct a resistive load using standard value resistors and to provide approximately a two-to-one margin of wattage safety for each resistor, we can round off the results to a series string of 134 resistors, each 250 ohm, 50 W in value. The resulting load will draw 298 mA at 10 kV, with each resistor dissipating 22 W. Applying Kirchhoff's Law, $R_p = R_1 \times R_2 / (R_1 + R_2)$, this resistive load could also be constructed from a series string of 134 assemblies, each consisting of two paralleled 500 ohm, 25 W resistors.

Figure 2

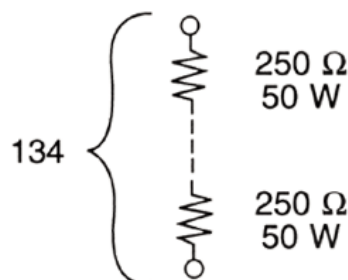

A situation may exist where a resistive load is required to develop two or more current levels from the same supply. In the example above, consider a load design that will produce currents of either 300 mA or 150 mA at 10 kV. Obviously, increasing the series string to 268 individual 250 ohm, 50 W loads will meet this requirement. Connecting the 10 kV supply to the top of this string will reduce the current to 10 kV/67 k ohm or 149 mA and the power drawn from the supply to 1.49 kW. Connecting the 10 kV supply to the mid-point of the string will produce the same results as in the original example. However, because of the lowered power demands on the top of the string, we can reduce both the number and wattage requirements on these upper resistors.

Considering only the top portion of the string:
 $V = 5 \text{ kV}$ (only 1/2 of the 10 kV appears across this section)
 $I = 149 \text{ mA}$

Then:

$$R = 5 \text{ kV} / 149 \text{ mA} = 33.6 \text{ k ohm}$$

$$P = 5 \text{ kV} \times 149 \text{ mA} = 745 \text{ W}$$

If we dissipate 10 W in each of the resistors in this upper section, which is possible because the total power has now been reduced to 1.5 kW, then:

$$n = 745 \text{ W} / 10 \text{ W} = 75$$

$$R_n = 33.6 \text{ k ohm} / 75 = 448 \text{ ohm}$$

$$V_n = 5 \text{ kV} / 75 = 66.6 \text{ V}$$

Again, to provide a power safety margin, we can round this upper section off to 67 series resistors, each 500 ohm, 25 W, to produce the following new resistive load.

Figure 3

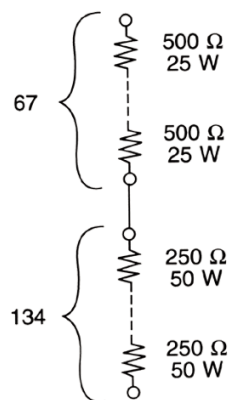

As an example of a design where voltage breakdown also must be considered, assume the following conditions:

$$V = 100 \text{ kV}$$

$$I = 10 \text{ mA}$$

$$P_n = 5 \text{ W}$$

Then:

$$R = 100 \text{ kV} / 10 \text{ mA} = 10 \text{ M ohm}$$

$$P = 100 \text{ kV} \times 10 \text{ mA} = 1 \text{ kW}$$

$$n = 1 \text{ kW} / 5 \text{ W} = 200$$

$$K_n = 10 \text{ M ohm} / 200 = 50 \text{ k ohm}$$

$$V_n = 100 \text{ kV} / 200 = 500 \text{ V}$$

If we again provide a two-to-one wattage safety margin, the resulting load will consist of a series of 200 resistors, where each resistor is 50 k ohm, 10 W in value. The resulting load will draw 10 mA at 100 kV with each resistor dissipating 5 W. The voltage drop across each resistor is a safe 500 V. However, because the applied voltage is 100 kV, the problem of possible voltage breakdown must be considered for this load. We will discuss this problem in the following section that addresses the question of how to construct a resistive load.

Figure 4

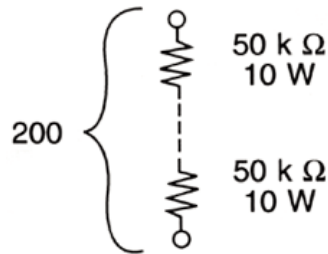

Voltage breakdown considerations can arise in other ways. Consider the previous example and assume that we wish to construct a load for the same 100 kV supply but with the maximum current reduced to 1 mA. The new conditions are:

$V = 100 \text{ kV}$
 $I = 1 \text{ mA}$
 $P_n = 5 \text{ W}$

Then:

$R = 100 \text{ kV} / 1 \text{ mA} = 100 \text{ M ohm}$
 $P = 100 \text{ kV} \times 1 \text{ mA} = 100 \text{ W}$
 $n = 100 \text{ W} / 5 \text{ W} = 20$
 $R_n = 100 \text{ M ohm} / 20 = 5 \text{ M ohm}$
 $V_n = 100 \text{ kV} / 20 = 5 \text{ kV}$

Depending on the type of resistors selected, the 5 kV drop across each series resistor could be excessive. A typical resistor may have, for example, a maximum voltage rating of 1 kV. If this is the case, we must increase the number of resistors from 20 to 100 to limit the drop across each resistor to 1 kV. Because of the increased number of resistors, both the resistance and power dissipated across each resistor are reduced by a factor of 1/5. The resulting load can then be constructed from a series string of 100 resistors, each 1 M ohm, 2 W in value.

Figure 5

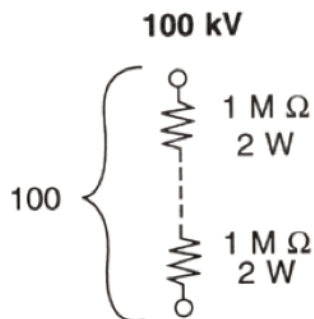

How to construct a resistive load

No special precautions are necessary to prevent voltage breakdown for loads designed to work up to 10 kV, or perhaps as high as 20 kV. Instead, the emphasis must be on mounting the resistors in such a way that an adequate flow of air is provided to dissipate the heat generated.

Shown below is a photograph of a typical configuration. Sheets of phenolic insulation are separated by drilled and tapped Delrin spacers. The resistors, in this case 50 watt wire wound resistors, are connected in series on the first sheet, as shown in the inset photograph, and then repeated sheet-by-sheet until the required number of resistors are installed. A freestanding fan can be positioned to draw air through the vertical sheets to cool such a load.

Figure 6

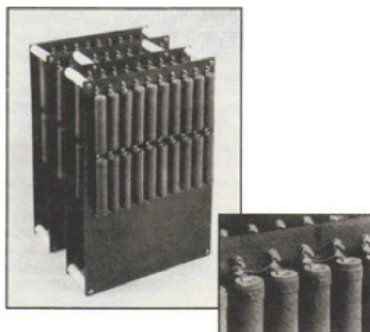

The construction of a resistive load designed to operate at a voltage higher than 10 kV is more complicated. Here the dual problems of heat dissipation and possible voltage breakdown must be addressed. Shown below is a photograph of a typical helical construction that solves both of these problems.

A framework of flame-resistant thermoplastic acrylic insulation, such as Lexan, is made by butt gluing two vertical pieces of plastic at right angles to and along the centerline of a main vertical piece to form a vertical cross of symmetrical cross section. This structure can be stiffened by gluing a series of small blocks of plastic where the surfaces butt together. Holes in the outer edges of the four vertical members will allow for the support of the resistor leads.

First, it is necessary to determine the size of this framework. Let's consider the earlier example where we designed a 100 kV load consisting of 200 individual 50 k ohm, 10 W resistors. If we plan on 12 resistors for each turn of the helix, we will need 16.7 turns to accommodate all 200 resistors. This means that the voltage difference between similar points on any two adjacent turns will be $100 \text{ kV} / 16.7$ or 6 kV. If we use a conservative safety factor of 1 inch of clearance for each 5 kV, the minimum vertical spacing between adjacent turns necessary to avoid voltage breakdown is $6/5$ or 1.2 inches. This means that the total height of the framework must be at least 1.2×16.7 or 20 inches. The width of the framework will be determined by the physical size of the resistors, remembering that each turn will contain 12 resistors, or 3 resistors between each adjacent vertical surface.

As shown in the inset photograph, we have used a small crimped sleeve to join each pair of resistor leads before soldering. When soldering, be sure to avoid sharp projections. Each joint should consist of smoothly rounded surfaces to prevent any concentration of electric fields.

Figure 6

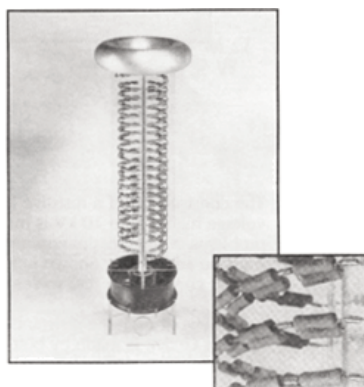

The entire framework can be mounted on an elevated base in which a fan is installed or, as in the example shown in the photograph, the fan frame itself can form the base of the load. To more efficiently direct the air flow from the fan through the helix, a sheet of mylar can be formed into a cylinder, using tape to seal the junction, and dropped over the helix. If necessary to prevent corona, an aluminum toroid can be connected to the top of the load to provide an equipotential surface at the point of highest voltage.

How to safely use a resistive load

As with any device that is connected to a high voltage power supply, the first safety requirement is to establish a stable, low impedance, zero potential level. This means that the ground terminal(s), marked E1, of the supply must first be connected to a good earth ground and then the grounded end of the load securely connected to E1.

The second safety requirement is to position the load so that there is adequate clearance between it and any grounded point or surface, including the operator! At Glassman, we have established a purposely-conservative rule of 1 inch of clearance for each 5 kV of output voltage. For example, 100 kV requires 20 inches of clearance.

The third safety requirement is to never touch any part of the load until, first, the supply is turned off and disconnected from the AC line and, second, the output of the supply is physically shorted to ground by an insulated wand to drain off any stored energy.

The fourth safety requirement is to make sure that the lead running from the output of the supply to the high potential end of the load is adequately supported to avoid any clearance problems with a grounded surface. If the lead is shielded, the shield should be connected to ground and stripped back at the high voltage termination by an amount equal to 1 inch for each 5 kV of output voltage.

In addition, the final safety requirement is common to any operation of a high voltage supply. No one should operate a high voltage supply alone. There should always be at least one other technically qualified person in the immediate area.